

HFS4-v3.1 for Ford Focus ST 2012 on v4 preliminary

This update: 2nd June 2016

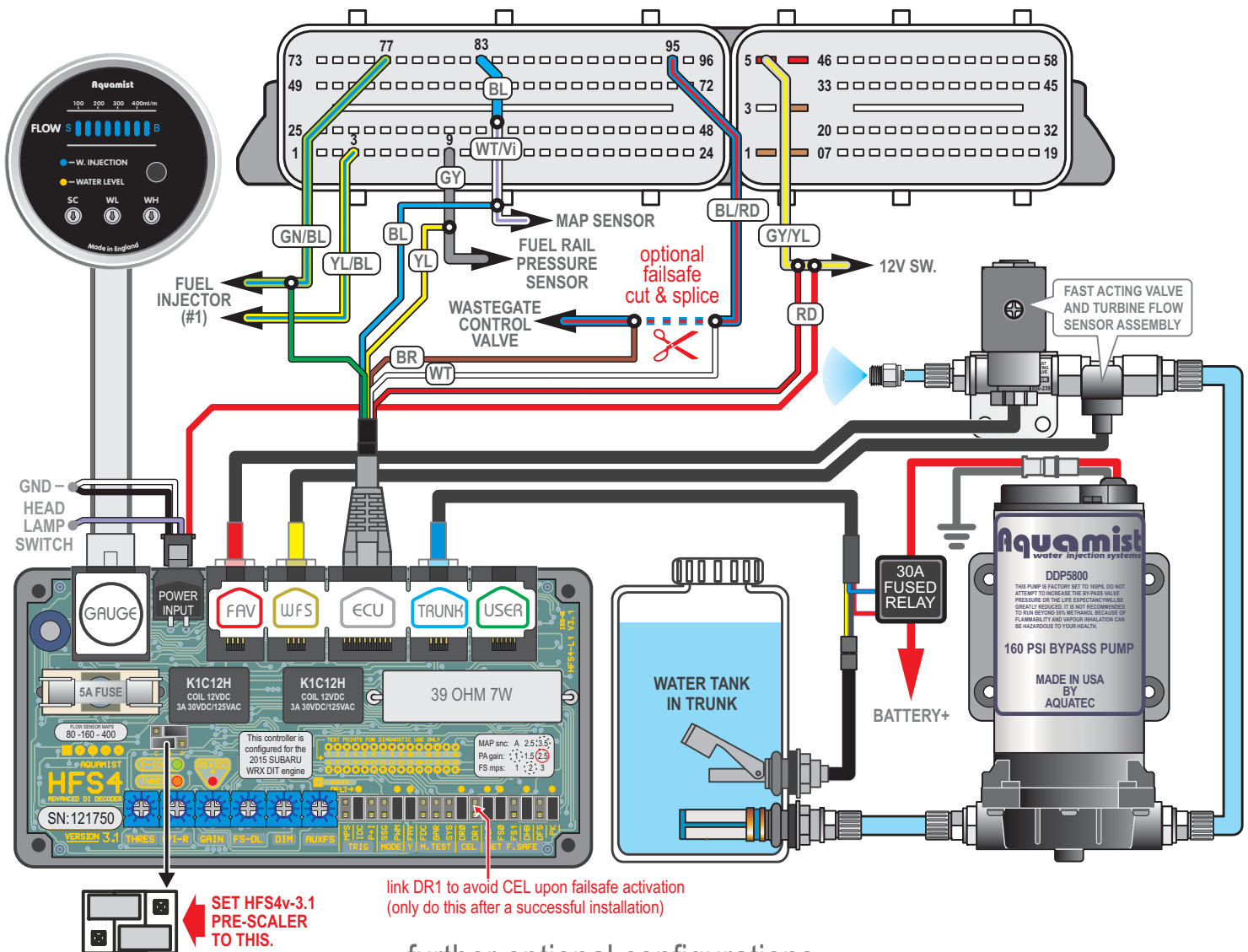

further optional configurations

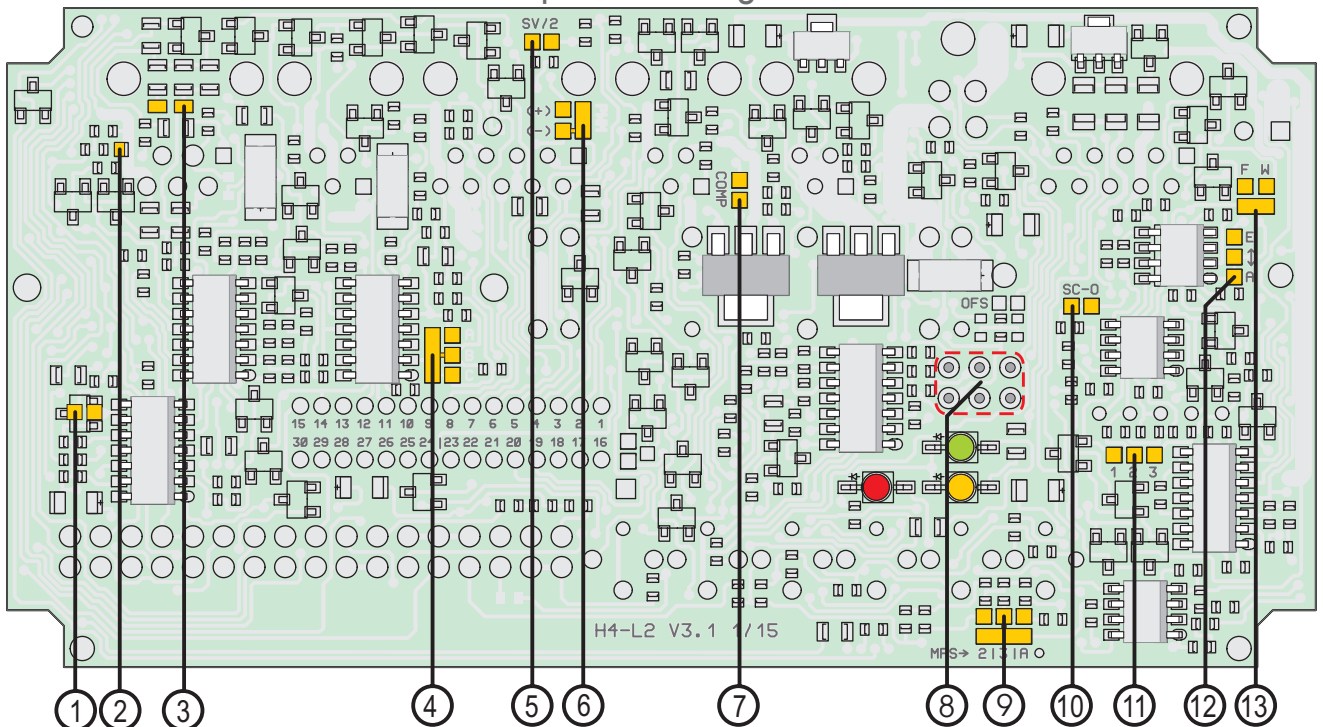

1. No modification
2. No modification
3. No modification
4. No modification
5. No modification

6. Cut "-" link, solder link "+" to large pad
7. Optional flow compensation from other 0-5V sensors
- 8-10. No modification
11. No modification
- 12-13. Optional failsafe from other 0-5V sensors